

SERLUX

ECO NEW PANDA Street light

50W / 100W / 150W





The manufacturer reserves all rights to make changes in the materials and components used in this products. All data is subject to change without prior notice.
The tolerance for all the given data is 10%

Product Description :

- The Ecobright series is ideal for new streets and for renovating existing installations, this affordable range of lighting solutions combines clean, high-quality light with significant energy savings and reduced maintenance.

Features :

- One to one replacement for 70W,100W, 150W and 250W conventional SON or HPL luminaires
- Reliable design with diecast aluminum housing
- Fully IP66 Ingress and IK08 mechanical impacts protection
- 10KV replaceable surge protection device
- 50,000 hours L80 at 25°C Ta rated lifetime
- Two luminaire efficiency options:
 - 115LM/W Luminaire efficiency
 - 150LM/W luminaire efficiency
- Operating temperature range - 30°C < Ta < 45°C
- Optimized optic for road and street lighting

Application :

- Road and Residential street
- Parking area
- Walking/cycling path

Specifications :

MINI



S



M



SERLUX

Model	MINI S M
Light source	Integral LED Module
Power	50W/100W/150W (Other power upon request)
Luminaire flux	2300-7500Lm(MINI) 6900-15000Lm(S) 13800-22500Lm(M)
Luminaire efficacy	115-160lm/W
CCT	4000K (3000K/5000K/5700K upon request)
CRI	> 70 > 80(upon request)
Lifetime	50,000 hours at 25°C ambient temperature
Operating temperature range	-30 to 45°C
Driver	Meanwell (Inventronics optional) Other brand of driver(upon request)
Electrical	Class I Input voltage: 90-305VAC/50-60Hz 10KV/20KV SPD
Dimming	1-10V PWM
Options	Photocell Nema Socket Surge protection device (up to 20KV) 0.5m External cable(Other length upon request) Smart control device
Materials	Housing: ADC12 die-cast aluminum Cover: PMMA lens Screws: 304 stainless screws
Color	Grey/ Black/ white
Tightness level	IP66
Impact Resistance	IK08
Standards & Certifications	CE (pending) CB (pending) IEC (pending) ROHS (pending) LM80 (pending) LM79 (pending)

Pictures :

SERLUX

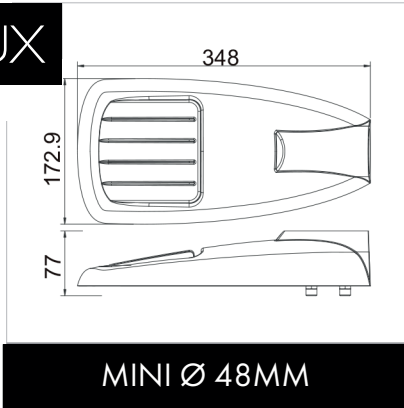

MINI Ø 48MM

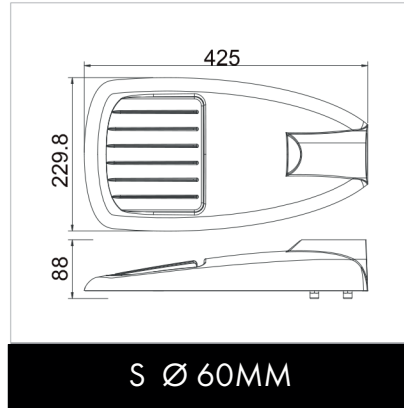

S Ø 60MM

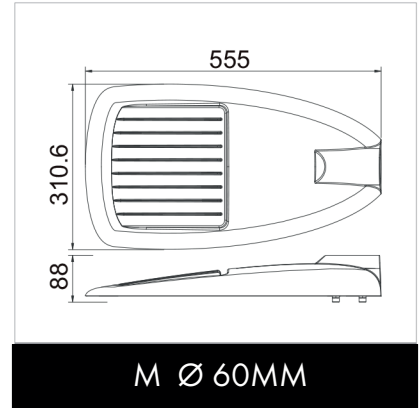

M Ø 60MM

Optional Accesories

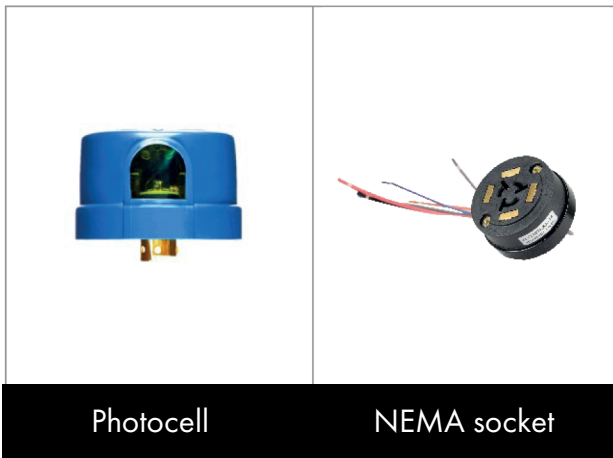

Photocell

NEMA socket

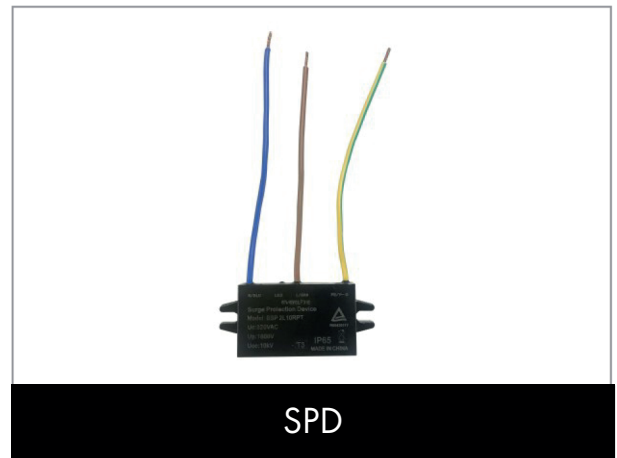

SPD

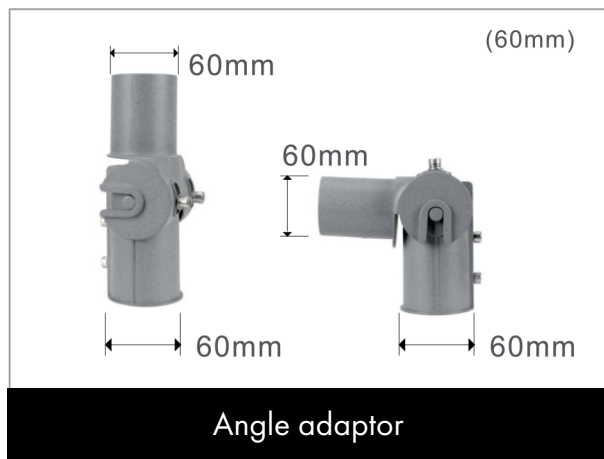

Angle adaptor

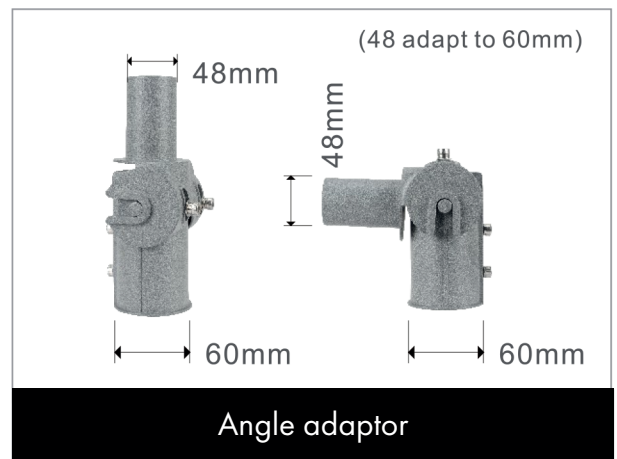

Angle adaptor

Model No	Color temperature	Input Voltage	Luminaire system output
MINI -50W	3000K/4000K/5700K	90-305VAC	7500LM
S -100W	3000K/4000K/5700K	90-305VAC	15000LM
M -150W	3000K/4000K/5700K	90-305VAC	22500LM

SERLUX

CARRASCO | CASA CENTRAL

Av. Italia 5672
2600 2028
092 792 893

PUNTA CARRETAS

Francisco Ros 2781
2711 7113
092 868 340

LAGOMAR

Av. Giannattasio KM 21.8
2698 5300
099 306 969

PUNTA DEL ESTE

Av. Italia esq. Patagonia
4249 5328
099 764 876